

Optimisation of the air suspension bracket for GL70 air suspension units

Progressively starting in the 1st quarter of 2022

General aspects

As part of the ongoing optimisation of GIGANT products, the air suspension bracket on air suspension units with 70 mm spring width (GL70L, GL70, GL70HD) and the axle lift accessories were examined in more detail. The focus was on easier handling of the components.

Conversion of the air suspension bracket began with the T-bracket starting in the 4th quarter of 2021. The other versions will follow progressively in 2022.

Generation 1 until 2022 with eccentric bush

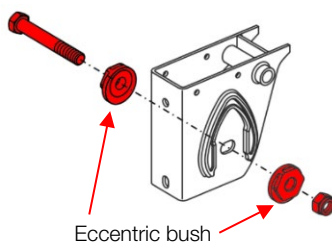

Generation 2 starts in the 1st quarter of 2022 without eccentric bush

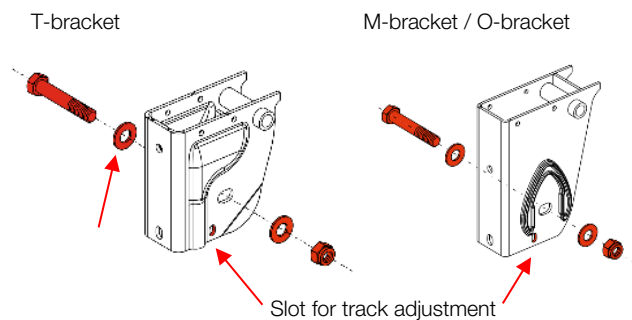

What will change?

- The T version of the air suspension bracket has **a stamping to reinforce** the side flanks, instead of the welded reinforcement plate.
- Instead of the eccentric bush (●), **high-strength washers** (○) will be used in the future on the spring bolt fitting. As a result, alignment of the eccentric bushings relative to each other will no longer be necessary.
- There is a **slot** on each side plate of the air suspension bracket, in which the **track adjustment tool** can be supported.
- **Track adjustment on one side** on each air suspension bracket using the track adjustment tool:
 - Tighten the spring bolt fitting until the spring bolt fitting can still be moved by hand.
 - Using the lever tool (703026395), whose pin is inserted in the slot of the air suspension bracket, the spring bolt fitting is moved back and forth and the track is adjusted.
 - After the track adjustment, the locknut of the spring bolt must be tightened to the prescribed torque, without moving the spring bolt fitting.

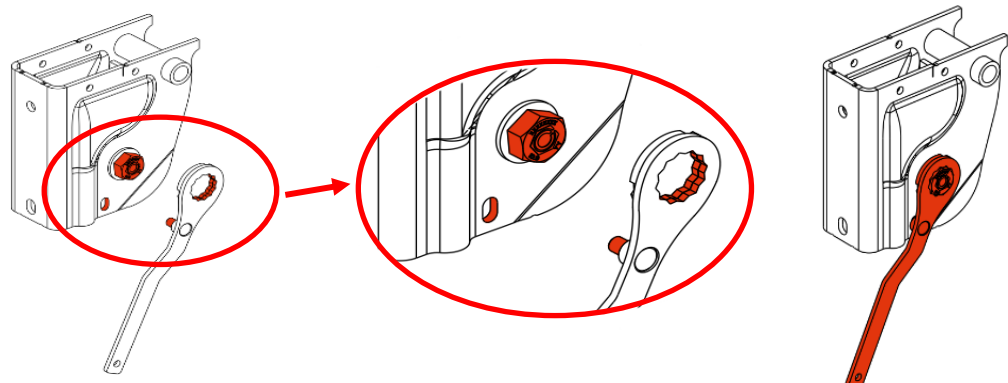

- The **one-part axle lift**, only for Generation 2 with its moving side plates with lugs, can be easily installed by one person.

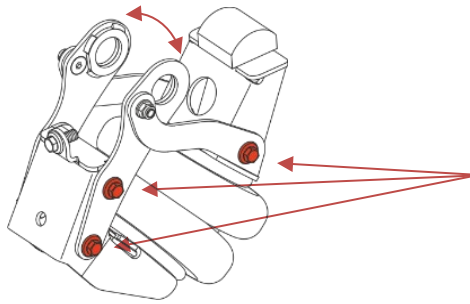

Screws loosened, spread the lugs, put on, tighten screws, connect air and finished!

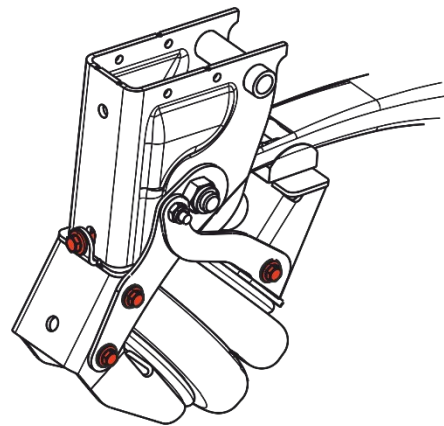

- The contour for welding on the chassis has changed due to the **changed design of the air suspension brackets** (T-bracket). If adjustments should be necessary on existing welding/assembly jigs, please contact your GIGANT partner.

The GIGANT team is happy to answer any questions you may have and wishes you a safe journey.

Created/reviewed:

Approved:

2021.12.14	HU	2021.12.20	AK
Date	Signature	Date	Signature